



## WAGGER ATTACHMENTS

---

### Installation/User/Maintenance/Spare Parts Manual

---

### WAGGER FORK POSITIONER

### FORK POSITIONER – FPM

---

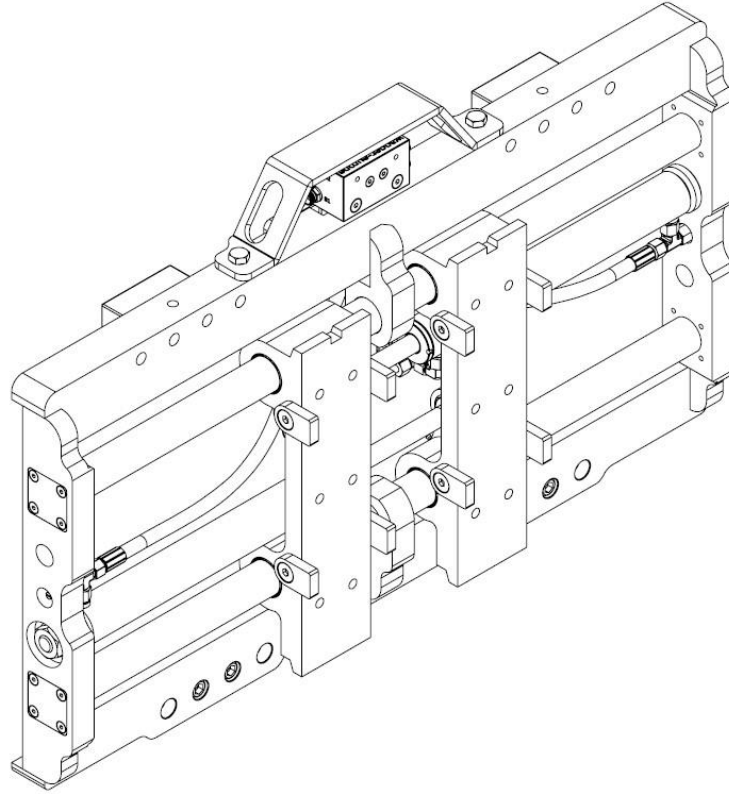

SERIAL NUMBER OF YOUR EQUIPMENT \_\_\_\_\_

---

**Carefully read the manual before use.**

**Glmak İstif Makinaları San. Ve Tic. Ltd. Őti.**

YeŐiloba Mah. 46247 Sk. No: 2/A Seyhan / ADANA / TRKİYE

# INDEX

PREFACE .....	1
Manual Information .....	1
GENERAL INFORMATION .....	2
DATA FOR CE CERTIFICATION OF EQUIPMENT .....	3
TECHNICAL SPECIFICATION.....	4
SAFE AND CORRECT USE .....	5
GENERAL SAFETY PRECAUTIONS .....	6
Safety Statements.....	6
Equipment Safety Precautions .....	7
STORAGE OF THE EQUIPMENT .....	8
Detaching Of The Equipment .....	8
Preparation For The Storage .....	8
Removing From Storage .....	8
MAINTENANCE OF THE EQUIPMENT .....	9
Maintenance Safety Precautions .....	9
Maintenance Procedure.....	10
HYDRAULIC HOSE REPLACEMENT.....	11
Disconnecting the Hydraulic Hose.....	11
Connecting the Hydraulic Hose .....	11
CYLINDER SEAL REPLACEMENT .....	13
Disassembly Procedure .....	13
Assembly Procedure .....	14
TROUBLESHOOTING .....	16
DECAL PLACEMENT .....	17
WARRANTY.....	18
END OF LIFE DISPOSAL.....	18
ASSEMBLY OF FORK POSITIONER – FPM .....	19
LIST OF SPARE PARTS - FL6FPMNH.....	20
MOUNTING KIT INSTALLATION - CYLINDER ASSEMBLY .....	21
LIST OF SPARE PARTS - SC6530A .....	22

## PREFACE

This manual provides you with all the information necessary for the installation, use and maintenance of your equipment. Its efficiency and lasting wear depends on effective maintenance and the care taken in its use.

**Gülmak İstif Mak. San. Tic. Ltd. Şti.** and your dealer are at your disposal to provide any information regarding operation and they also provide original spare parts to ensure perfect adaptation in the event of replacement.

Before leaving the factory, the equipment has been subjected to test to ensure maximum reliability.

Check to ensure that the equipment has not been subjected to the structural damage that may injure its functionality and safety.

The technical information provided in this manual are property of **Gülmak İstif Mak. San. Tic. Ltd. Şti.** and are confidential in nature: therefore even partial diffusion or reproduction of this manual is prohibited by law.

### Manual Information

The present manual is to be considered an integral part of the device and must accompany the same until such time as it is scrapped. In the event of loss or damage, request a new manual from the manufacturing company.

This manual contains information, safety cautions, instructions on installation, transport, function and maintenance information.

Thoroughly read the manual and keep it on hand.

In the event of any problems with either the equipment or the manual, contact **Gülmak İstif Mak. San. Tic. Ltd. Şti.** for the latest information available.

The manual, complete with all enclosures must accompany the equipment in the event of re-sale!

#### WARNING !



**Never let anyone operate this unit without reading the “Safety Precautions” and Operating Instructions” sections of this manual.**

Unless noted otherwise, right and left sides are determined from the operator’s control position when facing the attachment.

**NOTE: The illustrations and data used in this manual were current at the time of printing, however, we reserve the right of redesign and change the attachment as may be necessary without notification.**

### Before Operation

Make sure the equipment is operated only by trained operators that have read and understand this manual. If there is any portion of this manual or function you do not understand, contact your local authorized dealer or the manufacturer to obtain further assistance.

## **GENERAL INFORMATION**

### **Information on the *Fork Positioner (FPM)***

*FPM Fork Positioner* is a hydraulic equipment and requires one hydraulic function.

*FPM Fork Positioner* The demands on material handling tasks are increasingly more complex. WAGGER Fork Positioners accommodate these requirements, as they increase the flexibility and profitability with more handling capacity of every forklift truck.

Especially when the width of the load changes constantly. For this reason Fork Positioners are the most frequent attachment found on forklift trucks after sidershifters. And WAGGER offers a large variety of Fork Positioners - suitable for every transportation and operational task.

### **Operator Position**

The operator should control the equipment from the telehandler driver's seat.

### **Manufacturer Identification Data**

Gülmak İstif Makinaları San. Ve Tic. Ltd. Şti.  
Yeşiloba Mah. 46247 Sk. No: 2/A Seyhan / ADANA / TÜRKİYE  
Tel : +90 322 428 08 58 – Fax : +90 322 428 09 25

### **Technical Assistance**

Gülmak İstif Makinaları San. Ve Tic. Ltd. Şti.  
Use only Wagger Brand original spare parts.  
Gülmak İstif Makinaları San. Ve Tic. Ltd. Şti. declines any responsibility for the use of non-original spare parts.

## DATA FOR CE CERTIFICATION OF EQUIPMENT

The manufacturer will certify the equipment unit applying a plate on it indicating the residual capacity of the unit. This plate will also enable the traceability of the equipment.

Orders for spare parts must be accompanied by the serial number of the equipment written on the name plate.

### Equipment Identification Plate

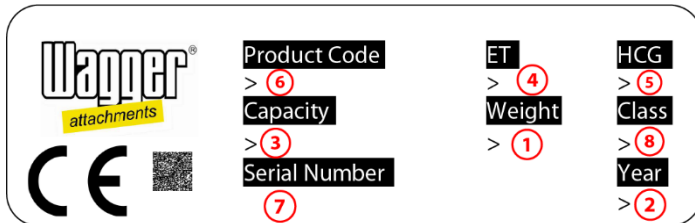

- 1 - Equipment weight
- 2 - Year of production.
- 3 - Equipment capacity
- 4 – Effective Thickness
- 5 - Equipment centre of gravity
- 6 - Product code
- 7 - Serial number
- 8- Mountaing Class

# TECHNICAL SPECIFICATION

## FPM SIDE SHIFTER & FORK POSITIONERS Heavy Duty Fork Positioners With Side Shifters

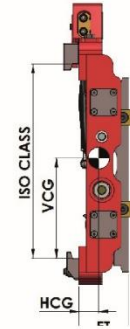
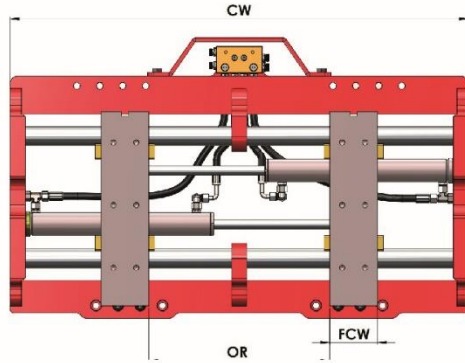

Catalogue Order No	Part No	Capacity (kg/mm)	Opening Range (mm)	Chassis Width (mm)	Mounting Class	Effective Thickness (mm)	Horizontal Centre of Gravity (mm)	Weight (kg)	Price
			OR	CW	ISO2328	ET	HCG	W	€
020FPM-A1080	FPN201080	2000/500	340-980	1080	2A	143	60	165	
025FPM-A1100	FPN251100	2500/500	340-1000	1100	2A	145	63	174	
035FPM-B1200	FPN351200	3500/500	385-1085	1200	3A	179	69	260	
040FPM-B1250	FPN401250	4000/500	385-1135	1250	3A	181	72	276	
045FPM-B1300	FPN451300	4500/500	385-1185	1300	3A	182	73	283	
050FPM-B1350	FPN501350	5000/500	440-1190	1350	3A	184	75	325	
050FPM-C1450	FPN501450	5000/600	480-1300	1450	4A	250	97	541	
060FPM-C1600	FPN601600	6000/600	480-1430	1600	4A	260	102	648	
070FPM-C1800	FPN701800	7000/600	480-1630	1800	4A	260	105	678	
080FPM-C2100	FPN802100	8000/600	480-1930	2100	4A	260	106	732	

- You may use it to position forks for pallet dimension.
- For heavy duty.
- 2 hydraulic function.
- Side shift feature available.
- Load backrest and forks are excluded.

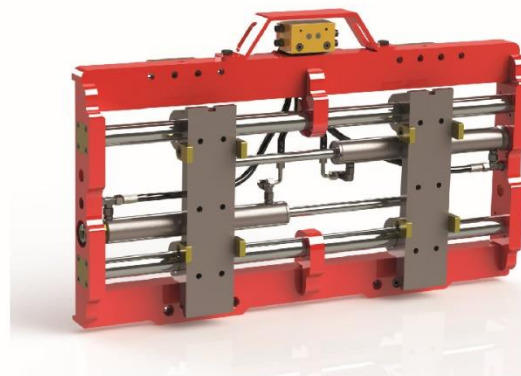

## **SAFE AND CORRECT USE**

### **Load Handling**

The effective filling way of the equipment is to position the equipment parallel to the ground and take the material.

Unload the material without touching of the front edge on the ground.

**NOTICE:** It is advisable to move the command lever smoothly; quick movements and stops may cause damages on hydraulic system of telehandler.



**WARNING !**

**Before Load Lifting;**





1. Check the all screws, pins and the condition of the carriage.
2. Check the correct assembly of the equipment to the telehandler and be sure that the screws of the lower hooks are tightened.
3. Operate the telehandler levers in order to find out which lever corresponds to what.

## GENERAL SAFETY PRECAUTIONS

### Safety Statements



**THIS SYMBOL BY ITSELF OR WITH A WARNING WORD THROUGHOUT THIS MANUAL IS USED TO CALL YOUR ATTENTION TO INSTRUCTIONS INVOLVING YOUR PERSONAL SAFETY OR THE SAFETY OF OTHERS. FAILURE TO FOLLOW THESE INSTRUCTIONS CAN RESULT IN INJURY OR DEATH.**

 DANGER	THIS SIGNAL WORD IS USED WHERE SERIOUS INJURY OR DEATH WILL RESULT IF THE INSTRUCTIONS ARE NOT FOLLOWED PROPERLY.
 WARNING	THIS SIGNAL WORD IS USED WHERE SERIOUS INJURY OR DEATH COULD RESULT IF THE INSTRUCTIONS ARE NOT FOLLOWED PROPERLY.
 CAUTION	THIS SIGNAL WORD IS USED WHERE MINOR INJURY COULD RESULT IF THE INSTRUCTIONS ARE NOT FOLLOWED PROPERLY.
 NOTICE	NOTICE INDICATES A PROPERTY DAMAGE MESSAGE.



**WARNING !**

**READ MANUAL PRIOR TO INSTALLATION**

Improper installation, operation, or maintenance of this equipment could result in serious injury or death. Operators and maintenance personnel should read this manual , as well as all manuals related to this equipment and the telehandler thoroughly before beginning installation, operation, or maintenance.

**FOLLOW ALL SAFETY INSTRUCTIONS IN THIS MANUAL AND THE TELEHANDLER 'S MANUAL.**



**WARNING !**

**READ AND UNDERSTAND ALL SAFETY STATEMENTS**

Read all safety decals and safety statements in all manuals prior to operating or working on this equipment. Know and follow good work practices when assembling, maintaining, repairing, mounting, removing or operating this equipment.

As well as safety regulations described in this section please take note of all the information provided in the manual of the telehandler onto which the equipment is to be mounted.



**WARNING !**

**KNOW YOUR EQUIPMENT**

Know your equipment's capabilities, dimensions and operations before operating. Visually inspect your equipment before you start and never operate equipment that is not in proper working order with all safety devices intact. Remove and replace any damaged, fatigued, or excessively worn parts. Make certain all safety decals are in place and are legible. Keep decals clean and replace them if they become worn or hard to read.

## Equipment Safety Precautions



**WARNING !**

### **DO NOT MODIFY EQUIPMENT**

Modifications may weaken the integrity of the attachment and may impair the function, safety, life and performance of the attachment. When making repairs, use only the manufacturer's genuine parts, following authorized instructions. Other parts may be substandard in fit and quality. Any modifications must be authorized in writing by the manufacturer.



**WARNING !**

### **USE CARE WITH HYDRAULIC FLUID PRESSURE**

Hydraulic fluid under pressure can penetrate the skin and cause serious injury or death. Hydraulic leaks under pressure may not be visible. Before connecting or disconnecting hydraulic hoses, read your telehandler's manual for detailed instructions on connecting and disconnecting hydraulic hoses or fittings. Wear safety glasses, gloves and protective clothing when searching for hydraulic leaks. Hold a piece of cardboard close to suspected leaks and then inspect the cardboard for signs of fluid. In the event of injury caused by hydraulic fluid under pressure, immediately seek medical assistance.



**WARNING !**

### **USE PERSONAL PROTECTIVE EQUIPMENTS**

It is recommended to use personal protective equipment during the operation of any attachment that may cause high levels of dust.



**WARNING !**

### **OPERATING THE EQUIPMENT**

- Do not use the equipment for any other purposes than those that have been intended.
- Do not exceed the maximum capacity as indicated on the identification plate.
- Never allow anyone to be around the equipment when it is operating.
- Do not operate the equipment from anywhere other than the correct operator's position.
- Do not leave the telehandler unguarded without having firstly lowered the load to the ground, pulled the hand brake and switched off the motor.
- Do not use the telehandler and equipment to transport people.
- Standing under the load is severely forbidden. Never pass the arm through the upright. Remain inside the driver's cabin.
- Approach ramps or climbs backwards. Driving downhill with the load in front reduces load stability.



### **TRANSPORTING THE EQUIPMENT**

- Travel only with the attachment in a safe transport position to prevent uncontrolled movement. Drive slowly over rough ground and on slopes.
- When driving on public roads use safety lights, reflectors, Slow Moving Vehicle signs etc. to prevent accidents. Check local government regulations that may affect you.
- Use extra care when loading onto or unloading the equipment from a trailer or telehandler.

## **STORAGE OF THE EQUIPMENT**

### **Detaching Of The Equipment**

1. Stop the motor of the telehandler.
2. Disconnect hydraulic connections between the equipment and the telehandler.
3. Loosen the screws and disconnect the lower hooks.
4. Operate the telehandler and remove the equipment.

### **Preparation For The Storage**

The following storage procedure will help you to keep your attachment in top condition. It will also help you get off to a good start the next time your equipment is needed. We therefore, strongly recommend that you take extra time to follow these procedures whenever your attachment will not be used for an extended period of time.

1. Clean the exterior thoroughly removing all mud, dirt and grease.
2. Inspect the unit for visible signs of wear. Order any parts required and make any necessary repairs to avoid delays when starting next season.
3. Tighten all loose screws.
4. Grease all grease fittings.
5. Seal hydraulic system from contaminants.
6. Replace decals if damaged or in unreadable condition.
7. Store the unit in a dry and protected place. Leaving the unit outside will materially shorten its life.

### **Removing From Storage**

1. Remove all protective coverings.
2. Check hydraulic hoses for deterioration and replace if necessary.

## MAINTENANCE OF THE EQUIPMENT

### Maintenance Safety Precautions



#### WARNING !

- Do not wear loose clothing or any accessories that can catch in moving parts. If you have long hair, cover or secure it so that it does not become entangled in the equipment.
- Work on a level surface in a well-lit area.
- Use properly grounded electrical outlets and tools.
- Use the correct tools for the job at hand. Make sure they are in good condition for the task required.
- Wear the protective equipment specified by the tool manufacturer.
- Before performing maintenance, lower the attachment to the ground, turn off the engine, remove the key and apply the brakes.
- Never perform any work on the attachment unless you are authorized and qualified to do so. Always read the operator service manual's before any repair is made. After completing maintenance or repair, check for correct functioning of the attachment. If not functioning properly, always tag "DO NOT OPERATE" until all problems are corrected.
- Worn, damaged or illegible safety decals must be replaced. New safety decals can be ordered from WAGGER.
- Never make hydraulic repairs while the system is under pressure. Serious personal injury or death could result.
- Never work under a raised attachment.

## Maintenance Procedure

Regular maintenance is the key to long equipment life and safe operation. Maintenance requirements have been reduced to an absolute minimum. However, it is very important that these maintenance functions be performed as described below.

PROCEDURE	DAILY	EVERY 40 HOURS
Check all bolts and nuts for tightness.	✓	
Replace any missing bolts or nuts with approved replacement parts.	✓	
Check hydraulic system for hydraulic oil leaks.	✓	
Visually inspect the equipment for cracked welds and repair as necessary. 	✓	
Check for missing or illegible Safety / Warning Decals.	✓	
Lubricate all grease fittings.		✓

Table 2

## HYDRAULIC HOSE REPLACEMENT

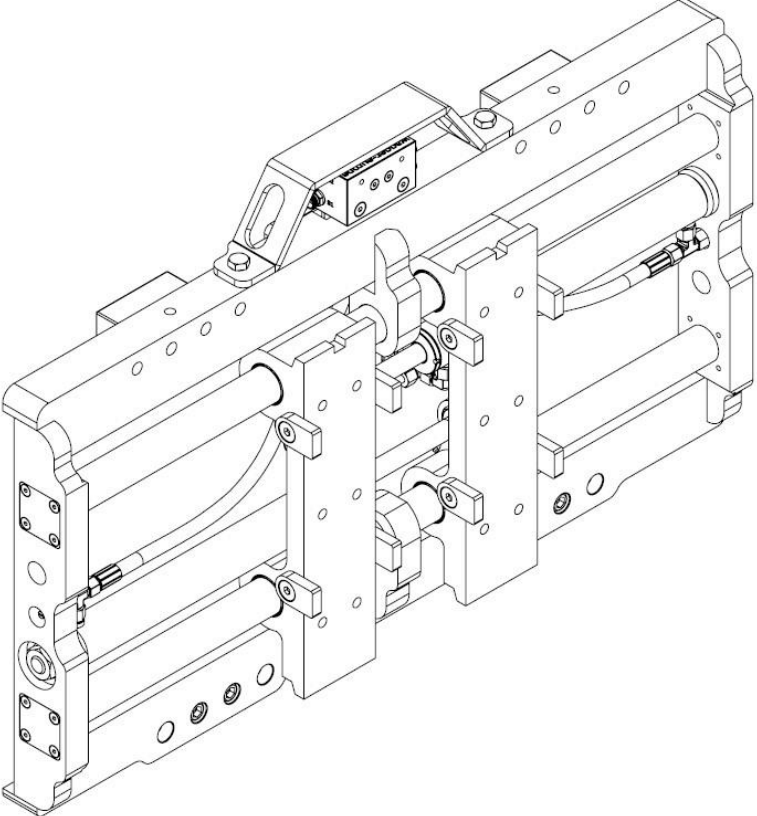

### WARNING !

Hydraulic fluid at system pressure can injure you. Before connecting or removing any hydraulic hose, residual hydraulic pressure trapped in the service hose line must be vented. Make sure the hose service line has been vented before connecting or removing hoses. Make sure the engine can not be started while the hoses are open. **Read “ Use care with hydraulic fluid pressure ” section of this manual in page 8.**

The following information is provided to assist you in the event you should need to replace a hydraulic hose.

### Disconnecting the Hydraulic Hose

1. Stop the engine.
2. Vent the hydraulic system.
3. Disconnect the hose.

### Connecting the Hydraulic Hose

1. Connect the hose.
  - a. Make sure that the hose is not twisted. Pressure applied to a twisted hose can cause the hose to fail or the connections to loosen.

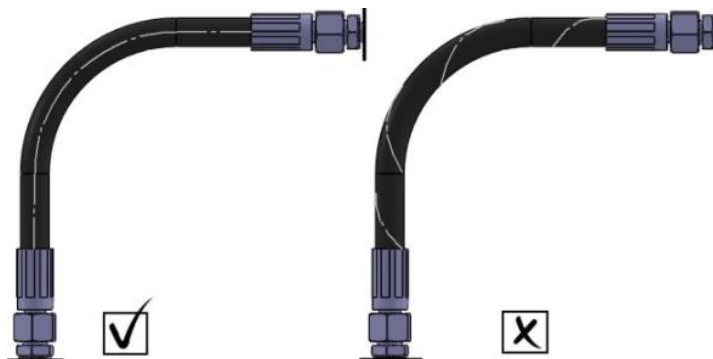

- b. Make sure that the hose does not touch hot parts. High ambient temperatures can cause the hose to fail.
- c. Make sure that the hose does not touch parts which can rub or cause abrasion.
- d. Use the hose clamps (where possible) to support long hose runs and keep the hoses away from moving parts, etc.

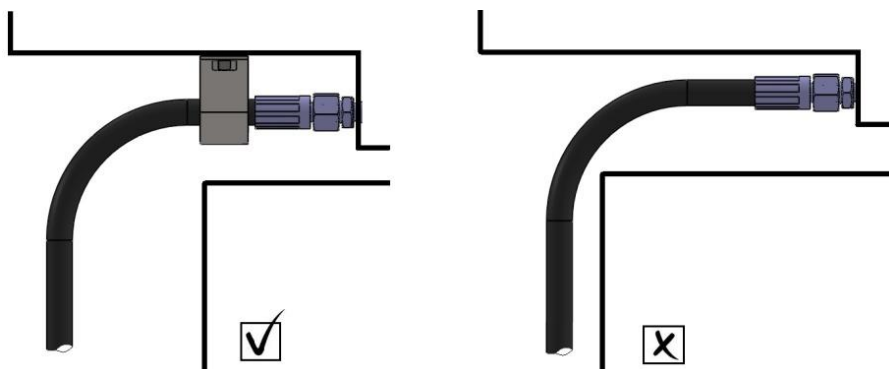

- e. To allow for length changes when the hose is pressurised, do not clamp at the bend. The curve absorbs the change.

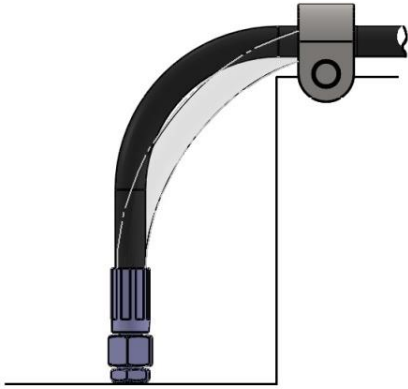

2. Start the engine
3. Operate the related control to increase the pressure in the hydraulic system.
4. Stop the engine then remove the starter key.
5. Check for indications of leakage at the hose connections.

## CYLINDER SEAL REPLACEMENT

The following information is provided to assist you in the event you should need to repair or rebuild a hydraulic cylinder. When working on hydraulic cylinders, make sure that the work area and tools are clean and free of dirt to prevent contamination of the hydraulic system and damage to the hydraulic cylinders. Always protect the active part of the cylinder rod (the chrome section). Nicks or scratches on the surface of the rod could result in cylinder failure. Clean all parts thoroughly with a cleaning solvent before reassembly.

### Disassembly Procedure

**IMPORTANT :** Do not contact the active surface of the cylinder rod with the vise. Damage to the rod could result.

#### THREADED TYPE GLAND

1. Rotate the gland with a spanner wrench counterclockwise until the gland is free of the cylinder tube.
2. Pull the cylinder rod from the cylinder tube and inspect the piston and the bore of the cylinder tube for deep scratches or galling. If damaged, the piston and the cylinder tube must be replaced.

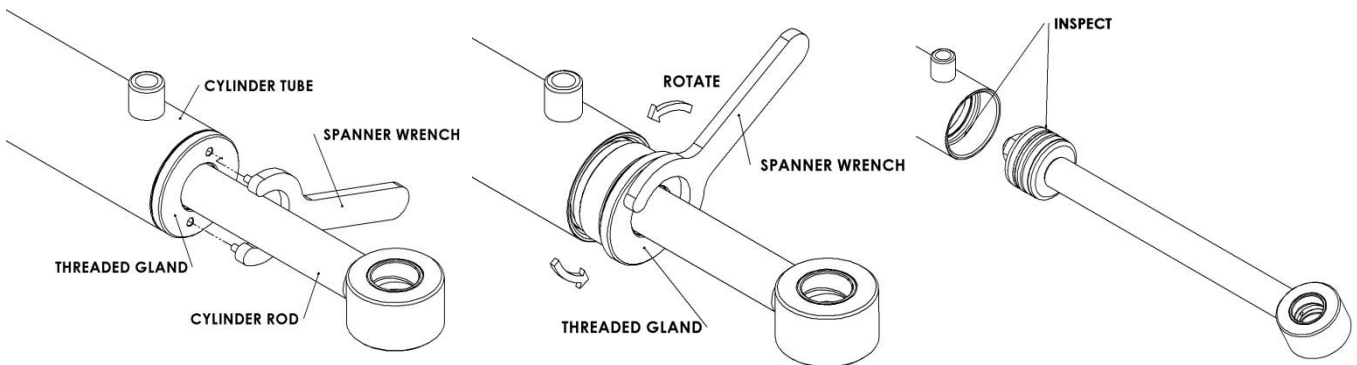

3. Remove the hex nut, piston, flat washer or spacer tube (if so required) and gland from the cylinder rod. If the cylinder rod is rusty, scratched or bent, it must be replaced.
4. Remove and discard all the old seals.

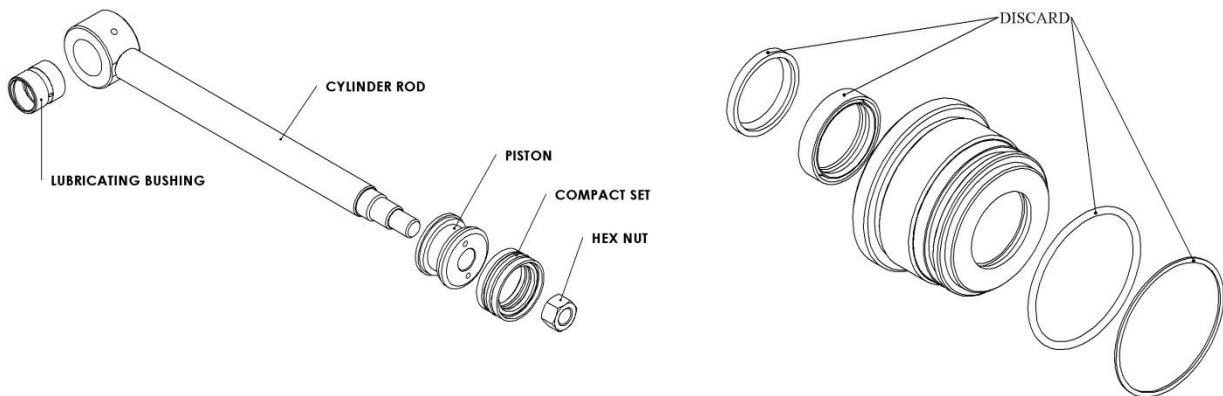

## Assembly Procedure

**IMPORTANT :** Replace all seals even if they do not appear to be damaged. Failure to replace all seals may result in premature cylinder failure.

**NOTE:** Seal kits will service most cylinders of similar bore size and rod diameter.

1. Install the cylinder rod seal in the gland first. Be careful not to damage the seal in the process, as it is somewhat difficult to install.

**NOTE:** A special installation tool is available to help with installing the seal. Simply fit the end of the tool over the seal so that the large prong of the tool is on the outside of the seal and the two smaller prongs on the inside. The lip of the seal should be facing towards the tool. Rotate the handles on the tool around to wrap the seals around the end of the tool.

Now insert the seal into the gland from the inner end. Position the seal in its groove, and release and remove the tool. Press the seal into its seat the rest of the way by hand.

2. Install the new piston ring, rod wiper, O-rings and backup washers, if applicable, on the piston.

Be careful not to damage the seals. Caution must be used when installing the piston ring. The ring must be stretched carefully over the piston with a smooth, round, pointed tool.

3. After installing the rod seal inside the gland, as shown in below Picture, install the external seal.
4. Slide the gland onto the cylinder rod, being careful not to damage the rod wiper. Then install the spacer or flat washer (if so equipped), small o-ring, piston and hex nut onto the end of the cylinder rod.



5. Secure the cylinder rod (mounting end) in a vise with a support at its center.
6. Apply a lubricant to the piston and teflon ring. Insert the cylinder rod assembly into the cylinder tube.

**IMPORTANT :** Ensure that the piston ring fits squarely into the cylinder tube and piston groove, otherwise the ring may be damaged and a leak will occur.





7. Use a spanner wrench to rotate the gland clockwise into the cylinder. Continue to rotate the gland with the spanner wrench until it is tight.

## TROUBLESHOOTING

PROBLEM	POSSIBLE CAUSE	POSSIBLE SOLUTION
<b>FPM will not operate.</b>	Auxiliary hoses not hooked up to the telehandler.	Engage Couplers.
	Obstruction in hydraulic lines.	Remove obstruction and replace if necessary.
<b>Leaking oil.</b>	Loose or damaged hydraulic line.	Tighten or replace.
	O-Rings on fittings damaged.	Replace if necessary.
	Fittings loose or damaged.	Tighten or replace.
	Cylinder seal damaged.	Replace cylinder seals.
<b>Insufficient power.</b>	Insufficient hydraulic flow from the telehandler.	Refer to telehandler's owners manual.
	Relief valve setting adjusted too low.	Refer to telehandler's owners manual.
	Oil filter on telehandler is dirty.	Refer to telehandler's owners manual.
<b>Cylinders operate in the wrong direction.</b>	Hoses from the valve to the telehandler incorrectly connected.	Switch couplers.
<b>A hydraulic cylinder not operating.</b>	Insufficient hydraulic flow from the telehandler.	Refer to telehandler's owners manual.
	Cylinder rod bent.	Visually inspect the cylinder for damage.
	Cylinder seals damaged.	Replace cylinder seals.
	Obstruction in hydraulic lines.	Remove obstruction and replace if necessary.
<b>Hydraulic cylinders only operating in one direction.</b>	Contaminants in the hydraulic system and solenoid valve.	Remove spool from solenoid valve and check for foreign material. Clean and replace.

## DECAL PLACEMENT

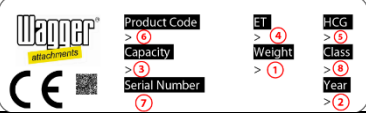
The drawing on this page shows the location of the decals used on FPM. The decals are identified by their part numbers, with reductions of the actual decals located on this page. Use this information to order replacements for lost or damaged decals. Be sure to read all decals before operating the FPM. They contain information you need to know for both safety and attachment longevity.

PART NO	DESCRIPTION	IMAGE
2311	LUBRICATION POINT	
2312	BRAND NAME	
2313	NAME PLATE	
2314	WARNING	 <ol style="list-style-type: none"> <li>1. Carefully read the manual before using the equipment and undertaking the maintenance operations.</li> <li>2. Risk of limb crushing.</li> <li>3. Pressurized liquids.</li> </ol>

**IMPORTANT:** Keep all safety decals clean and legible. Replace all missing, illegible or damaged safety decals.

**REPLACING SAFETY DECALS :** Clean the area of application with a nonflammable solvent, then wash the same area with soap and water. Allow the surface to dry. Remove the backing from the safety decals, exposing the adhesive surface.

## **WARRANTY**

For a period of 12 months, or 2.000 work hours (whichever comes first), from the date of delivery to customer, Wagger Attachments, at its option, will repair or replace for the original purchaser, free of charge, any part or parts of the attachment found, upon examination by Wagger Attachments, to be defective in material or workmanship, or both.

This warranty does not apply if such defect has been caused by alteration, improper use, failure to provide proper maintenance or operation contrary to Wagger Attachment's installation and service instructions. There is no other express warranty.

Wagger Attachments assumes no responsibility for damage or injury, either direct or consequential, resulting from or occasioned by possession or use of its products.

In case of dispute or controversy, resolution of such dispute shall fall under the legal jurisdiction of the Court of the city where the goods were manufactured.

## **END OF LIFE DISPOSAL**

At the completion of the useful life of the unit, drain all fluids and dismantle by separating the different materials (rubber, steel, plastic, etc.). Follow all federal, state and local regulations for recycling and disposal of the fluid and components.

# ASSEMBLY OF FORK POSITIONER – FPM

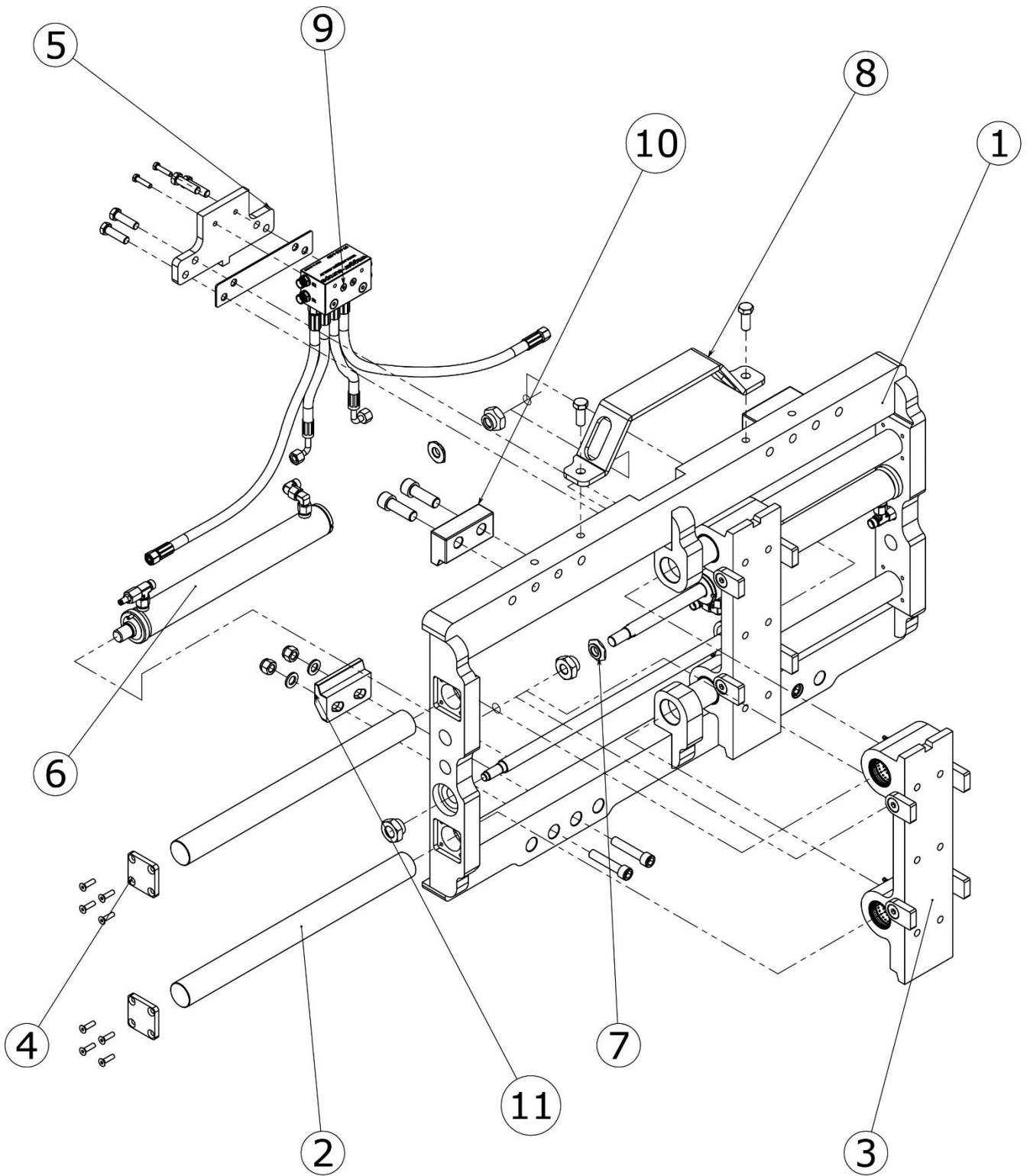

## **LIST OF SPARE PARTS – FLFPMNHL CASI**

<b>REF.</b>	<b>PART NO</b>	<b>DESCRIPTION</b>	<b>QTY.</b>
1	FPMI3501-010	FRAME	1
2	FPMI3501-105	SHAFT	4
3	FPMI3501-012	FORK CARRIER	1
4	FPMI3501-112	PLATE	4
5	FPMI3501-113	PLATE	1
6	FPMI3501-013	CYLINDER	2
7	OBESM20-103	NUTS	2
8	FPMI3501-114	VALVE PROTECTION	1
9	DM1459-0102	VALVE ASSY'	1
10	HK309	UPPER HOOK	2
11	HK308	LOWER HOOK	2

## MOUNTING KIT INSTALLATION - CYLINDER ASSEMBLY

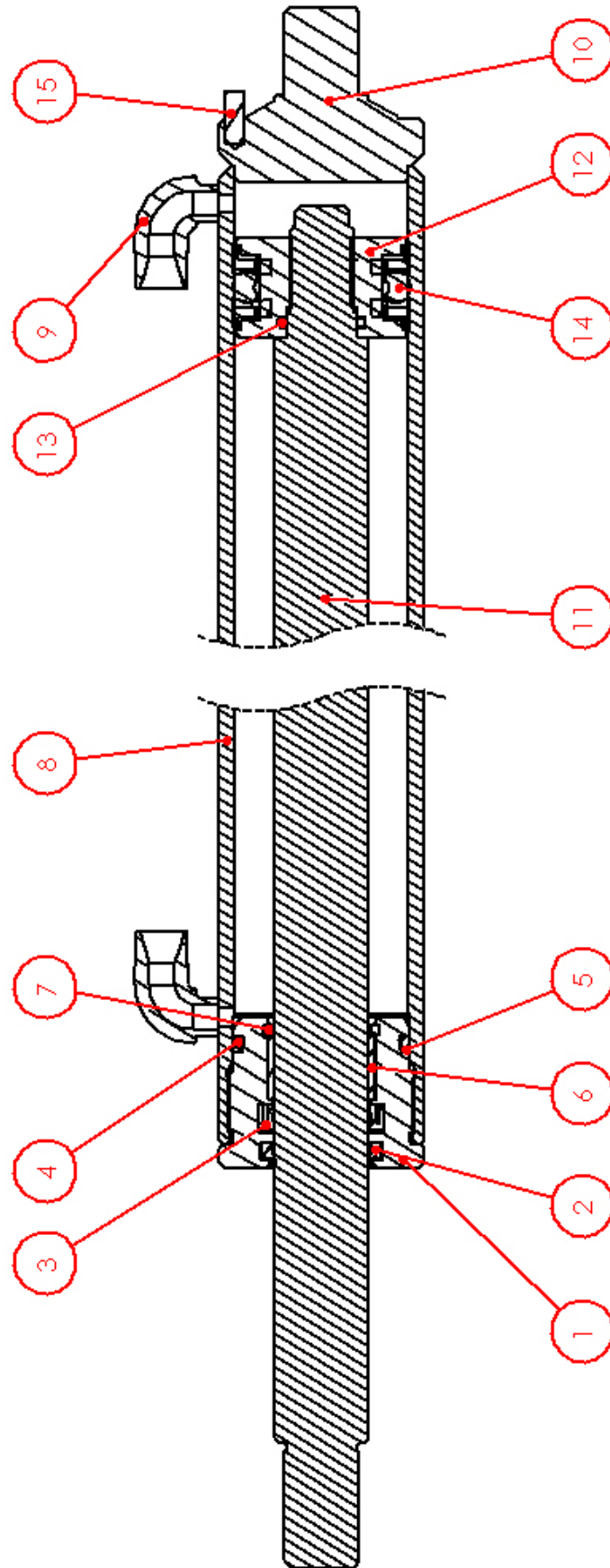

## LIST OF SPARE PARTS - SC6530A

ITEM	CODE	DESCRIPTION	QTY
1	SC6530A-Gland(Kep)	GLAND	1
2	Ø30xØ38-7-Wiper Ring(Toz keçesi)	WIPER RING	1
3	Ø30xØ40-8-Seal(Yağ Keçesi)	SEAL	2
4	Ø49x3.53-O-ring	O-RING	1
5	Ø51xØ56-1.5-Back-up Ring(Yastık)	BACK-UP RING	2
6	Ø65xØ55-Bushing(Burç)	BUSHING	1
7	Ø3xØ31-O-ring	O-RING	1
8	SC6530A-Shell(Boru)	SHELL	1
9	Nipel 90°	NIPEL	1
10	SC6530A-Back Gland	BACK GLAND	1
11	SC6530A-Rod(Mil)	ROD	1
12	SC6530A-Piston	PISTON	1
13	Ø22x3-O-ring	O-RING	1
14	0143-34-50-20,50-Compact Set	COMPACT SET	1
15	SC6530A-Pim	PIM	1

